

VDX-10K

10 kVA AC/AC converter

GENERAL FEATURES:

- Sine wave output voltage
- Suitable for motors control
- Adjustable output frequency
- Adjustable output voltage
- Remote ON/OFF opto-coupled
- Alarm by isolated relay contacts
- Configurable input: Reverse or Mid power
- Remote control via RS232 or CAN Bus
- Railway according to EN50155:2021
- Fire and smoke: EN45545-2:2020



3 YEAR
WARRANTY
INDUSTRY

ROHS
REACH

5 YEAR
WARRANTY
RAILWAY

EN50155

EN45545
fire & smoke

MODEL	VDX-10K-4501
Voltage line	400V three phase

VDX-10K-4501

400V three phase

**INPUT**

Nominal AC Voltage	400 Vac three phase sinusoidal
Minimum AC Voltage	360 Vac
Maximum AC Voltage	460 Vac
Frequency range	47...63 Hz
Power factor	> 0.55
Inrush current	< 10 A
Efficiency	> 95%

OUTPUT

Nominal output voltage (Von)	400 Vac Three phase sinusoidal
Output voltage range	15...110% of Von nominal (adjust via remote control)
Output frequency	5...100 Hz via RS-232 and CANBUS
Load regulation	< 4.5%
Line regulation	< 2% @ Vin ≥ 415 Vac < (Vin-15) + 2% @ Vin < 415 Vac
Output wave distortion THD	< 5% (average of 16 samples)
Output HF ripple	< 2.5%
Maximum Active power	10 kW Nominal
Maximum Apparent power	10 kVA Nominal
Maximum continuous current	14.43 A

ENVIRONMENTAL

Storage temperature	-25 ... 80 °C
Operating temperature: Full load	-40 ... 55 °C (EN50155:2021 OT2)
Operating temperature: 62.5 % load	-40 ... 70 °C (EN50155:2021 OT4)
Operating temperature: 25 % load	-40 ... 85 °C (EN50155:2021 OT6)
Relative humidity without condensation	5 ... 95%
Maximum altitude	2000m at full load, 2500m at 95% of load
Cooling	Internal controlled internal fan
Shock and Vibrations according to	EN61373:2011 Category 1 Class B body mounted
MTBF (MIL-HDBK-217-E; Gb, 25°C)	100.000 h

EMC

Immunity according	EN50121-3-2:2016/A1:2019
Emissions according	EN50121-3-2:2016/A1:2019

SAFETY

Dielectric strength: (Input & Output) / Earth	1800 Vrms / 50Hz / 1min
Dielectric strength: (Input & Output) / Signals	1500 Vrms / 50Hz / 1min
Dielectric strength: Signals / Earth	500 Vrms / 50Hz / 1min
Safety according to	EN62368-1, EN50124-1 Railway app. (Insulation coordination)
Pollution degree	PD2
Overvoltage category	OV2
Fire and smoke	EN45545-2:2020

MECHANICAL

Weight	< 6250 g
Case material	Aluminium 5754 H111
Case Finish	Anodized AA15
Protection degree	IP20
PCB protection	Acrylic transparent coating with UV mark

PROTECTIONS

Against overloads	Current and I ² T limited (see overload protection curve)
Against over-temperature	Shutdown with auto-recovery



CONTROL

Output OK LED	Green
Input OK LED	Green
Alarm LED	Red
Input alarm	Open when alarm. Maximum rating: 0.16 A at 160 Vdc
Output alarm	Open when alarm. Maximum rating: 0.16 A at 160 Vdc
Remote OFF input	OFF applying 15...143 Vdc (acc. to EN50155), Impedance >35 kΩ
Configurable input (reverse or mid-power)	ON: applying 15...143 Vdc (acc. to EN50155), Impedance >35 kΩ

Note-1: Is not recommended to handle connectors below -25°C



BLOCK DIAGRAM

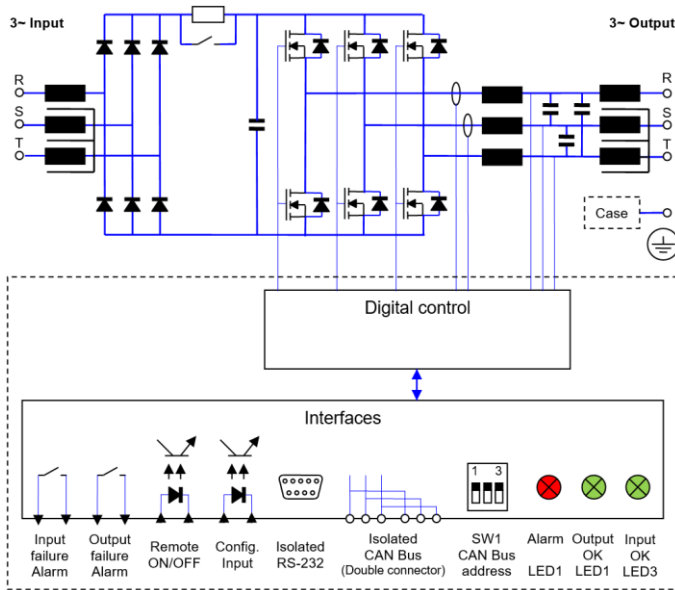

CONNECTIONS

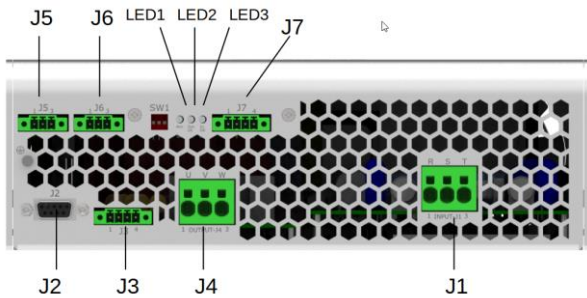

J1-1	Input R	Cables 2.5 ... 4mm ²
J1-2	Input S	
J1-3	Input T	
J4 - 1	Output U	Cables 2.5 ... 4mm ²
J4 - 2	Output V	
J4 - 3	Output W	
J3 - 1	+ Configurable input	Phoenix Contact MC1.5/4-GF-3.81 Recommended female: Phoenix Contact MC1.5/4-STF-3.81
J3 - 2	- Configurable input	
J3 - 3	+ Remote	
J3 - 4	- Remote	
J7 - 1, 2	Output alarm	Phoenix Contact MC1.5/3-GF-3.81 Recommended female: Phoenix Contact MC1.5/3-STF-3.81
J7 - 3, 4	Input alarm	
J5 - 1	CAN L	Phoenix Contact MC1.5/3-GF-3.81 Recommended female: Phoenix Contact MC1.5/3-STF-3.81
J5 - 2	CAN H	
J5 - 3	GND CAN	
J6 - 1	CAN L	Phoenix Contact MC1.5/3-GF-3.81 Recommended female: Phoenix Contact MC1.5/3-STF-3.81
J6 - 2	CAN H	
J6 - 3	GND CAN	
J2 - 2	RS-232 Rx	Female D-Sub DB9
J2 - 3	RS-232 Tx	
J2 - 5	RS-232 GND	
J2 rest	Not connected	
J8	Earth	M5 stud (Max torque 3 Nm)

POWER DERATING vs AMBIENT TEMP.

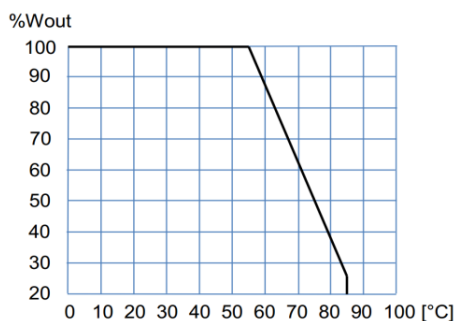

DESCRIPTION

The VDX-10k consists of three phase sine-wave AC-AC converter.

The unit allows:

- Shutdown the output applying a voltage from 15 to 143Vdc on pins 3 and 4 of J3.
- Start-up motors by means of a soft start. In the start-up, the output voltage rises linearly from 0V to set voltage and the frequency from the initial to the set one. The start-up ramp slope may be configured via RS-232 or CAN Bus
- Set the rotation speed of a motor according to the appropriate Voltage/Frequency ratio.
- Configurable input (pin 1 and 2 of J3) allows to configure the unit via RS-232 or CAN Bus for the functions below:
 - Reverse mode (by default): Changing the rotation direction for the next start-up of a motor by applying a voltage between 15 and 143V.
 - Mid power mode: Changing the output frequency in V/F mode from nominal to a mid-power frequency by applying a voltage between 15 and 143V.
- Monitoring the status of the input and output voltage through the contacts of two separate solid-state relays.
- Set and monitor parameters via RS-232.

The VDX-10k is equipped with a maximum average power protection as well as maximum output peak current protection. This protects the semiconductors even when an output short-circuit occurs. It also features a disable function for input under-voltage.

INSTALLATION

- The unit has 6 threaded holes for the fixation on a mounting surface.
- The unit has internal fans. For an appropriate cooling, the air input and output should be free of elements that cause and an air flow reduction (minimum recommended distance to other objects 90mm).
- Make connections as shown in the figure.

For safety reasons, the following requirements must be met:

- Provide the equipment with some kind of protective enclosure that complies with the electrical safety directives in effect within the country where the equipment is installed.
- Include an input fuse with a rating immediately higher than the maximum input current.
- Use cables of adequate cross-section to connect inputs and outputs. The following table lists the maximum currents and the minimum cross-sections for the cables used for each power connection.

	Input 400Vac	Output 400Vac
Maximum current	30 A	14.4A
Cable cross-section	4 mm ²	2.5 mm ²



RS232 communication port

It is possible to control and monitor the unit via RS232 by means of a terminal emulator like "Tera Term" or "Putty". Also it is possible to control and monitor the unit directly using the protocol showed in table:

Protocol configuration: ASCII code, 57600 bauds, parity none, 8 bits, 1bit stop

Header	Function	Parameter	Returns	Explanation		
P	L	V	PTV####	Input voltage in Volts		
		U	PTURS=#### [13]UST=#### [13]UTR=####	Output voltage in Volts RMS Phase-Phase ([13] = char 13 of ASCII code)		
		I	PTIR=#### [13]IS=#### [13]IT=####	Output current in Amps RMS ([13] = char 13 of ASCII code)		
		T	PTT####	Internal temperature in K		
		F	PTF####	Nominal output frequency in Hz		
		f	PTf####	Actual output frequency in Hz		
		y	PTu####	Actual output voltage set-point in V		
		S	PTS####	Inverter state 999.9 → Enabled 000.0 → Disabled 222.2 → Blocked by overload 111.1 → Blocked by overload or shortcircuit		
		M	PTM####	Model number		
		R	PTR####	Firmware version		
		Other	PTE	Command not supported		
		R	G	1	####	OK / ERR Set the low input voltage timed shutdown in V
	2			####	OK / ERR Set the minimum alarm input voltage in V	
	3			####	OK / ERR Change the status bit (after start up enabled with SW3 =LOCAL and disabled with SW3 =REMOTE) 999.9 → Inverter enabled 000.0 → Inverter disabled	
	4			####	OK / ERR Set the output voltage Phase-Phase in Vrms (Vo)(output must be stopped) 060.0 ≤ #### ≤ 400.0	
	5			####	OK / ERR Set the maximum output current in Arms 20% I _{nom} ≤ #### ≤ 100% I _{nom}	
	6			####	OK / ERR Set the nominal output frequency in Hz (Fo) (output must be stopped) 005.0 ≤ #### ≤ 100.0	
	7			####	OK / ERR Set the alarm maximum output current 0 < #### ≤ 100% I _{max_warning}	
	8			####	OK / ERR 111.1 → Reset the inverter	
	L			####	OK / ERR Set the minimum input starting voltage in Volts	
	O			####	OK / ERR Set the initial frequency in the startup (Fi) 005.0 ≤ #### ≤ 100.0	
	P			####	OK / ERR Set the ramp-up in increment of "N" cycles per Hz in mode V/F, frequency changes or start-up (Note-1) 001.0 ≤ #### ≤ 100.0	
	Q			####	OK / ERR Set the ramp-down in decrement of "N" cycles per Hz in mode V/F (Note-1) 002.0 ≤ #### ≤ 100.0	
	Y			####	OK / ERR Change the working mode of the input J4-1,J4-2 111.1 → Input as reverse phase control (default) 222.2 → Input as mid-power control (Note-2)	
	X			####	OK / ERR Set the mid-power frequency for V/F mode by the use of input J4-1,J4-2 005.0 ≤ #### ≤ 100.0	
	M			1	####	OK / ERR Set a new output frequency in Hz (output must be run and not stored in memory) 005.0 ≤ #### ≤ 100.0
				2	####	OK / ERR Set a new output voltage in Volts (output must be run and not stored in memory) 060.0 ≤ #### ≤ 400.0
		3	####	OK / ERR Set a new output frequency in Hz in mode V/F (output must be run and not stored in memory) 005.0 ≤ #### ≤ 100.0		
		4	####	OK / ERR Changes the output phase order (output must be run and not stored in memory) 111.1 → Phase RST (direct phase) 222.2 → Phase SRT (reverse phase)		



CAN communication port (optional)

It is possible to control and monitor the unit using the CAN connection with the CANOpen protocol. It is provided an .eds file with all the objects available.

Protocol configuration: 125kbit/s, NODE ID: 10 to 17. Selectable by means of dip switch, binary combination + 10.

The most relevant objects can be found in the following table:

Index	Subindex	Name	Type	Attribute	Explanation
0x6001	0x00	Input voltage	UINT32	ro	Input voltage in tenths of Volt
0x6003	0x01	Vrs	UINT32	ro	Output voltage in Volts Phase R-S
0x6003	0x02	Vst	UINT32	ro	Output voltage in Volts Phase S-T
0x6003	0x03	Vtr	UINT32	ro	Output voltage in Volts Phase T-R
0x6004	0x01	IR	UINT32	ro	Output current in hundredths of Amp Phase R
0x6004	0x02	IS	UINT32	ro	Output current in hundredths of Amp Phase S
0x6004	0x03	IT	UINT32	ro	Output current in hundredths of Amp Phase T
0x6005	0x00	Internal temperature Secondary	UINT32	ro	Internal temperature1 in tenths of K
0x6007	0x00	Nominal output frequency	UINT32	ro	Nominal output frequency in Hz
0x6008	0x00	Actual output frequency	UINT32	ro	Actual output frequency in Hz
0x6009	0x00	Actual output voltage set-point	UINT32	ro	Actual output voltage set-point in V
0x600A	0x00	Inverter state	UINT16	ro	Inverter state 3 → Enabled 0 → Disabled 2 → Blocked by overload 1 → Blocked by overload or shortcircuit
0x600B	0x00	Product ID	UINT16	ro	Model number
0x600C	0x00	Firmware version	UINT16	ro	Firmware version
0x6100	0x00	Low input voltage timed shutdown	UINT32	rw	Set the low input voltage timed shutdown in tenths of V
0x610B	0x00	Input voltage minimum warning	UINT32	rw	Set the minimum alarm input voltage in tenths of V
0x6101	0x00	AC status bit	UINT8	rw	Change the status bit (after start up enabled with SW3 =LOCAL and disabled with SW3 =REMOTE) 1 → Inverter enabled 0 → Inverter disabled
0x6102	0x00	Nominal output voltage	UINT32	rw	Set the output voltage Phase-Phase in Vrms (Vo) (output must be stopped) $60 \leq X \leq 400$
0x6103	0x00	Maximum output current	UINT32	rw	Set the maximum output current in Arms (per mille) $200\% I_{nom} \leq \text{■■■■} \leq 1000\% I_{nom}$
0x6104	0x00	Nominal frequency	UINT32	rw	Set the nominal output frequency in Hz (Fo) (output must be stopped) $5 \leq x \leq 100$
0x6105	0x00	Alarm maximum output current	UINT32	rw	Set the alarm maximum output current in Arms (per mille) $0\% \leq x \leq 1000\% I_{max_warning}$
0x6106	0x00	Inverter reset	UINT8	wo	1 → Reset the inverter
0x6107	0x00	Minimum starting input voltage	UINT32	rw	Set the minimum input starting voltage in tenths of Volts
0x6108	0x00	Start frequency	UINT32	rw	Set the initial frequency in the startup (Fi) $5 \leq x \leq 100$
0x6109	0x00	Ramp up value	UINT32	rw	Set the ramp-up in increment of "N" cycles per Hz in mode V/F, frequency changes or start-up (Note-1) $1 \leq x \leq 100$
0x610A	0x00	Ramp down value	UINT32	rw	Set the ramp-down in decrement of "N" cycles per Hz in mode V/F (Note-1) $2 \leq x \leq 100$
0x6120	0x00	confi_inversion	UINT8	rw	Change the working mode of the input J4-1,J4-2 0 → Input as reverse phase control (default) 1 → Input as mid-power control (Note-2)
0x6121	0x00	Mid_power_frequency	UINT32	rw	Set the mid-power frequency for V/F mode by the use of input J4-1,J4-2 $5 \leq x \leq 100$
0x6200	0x00	Runtime target frequency	UINT32	wo	Set a new output frequency in Hz (output must be run and not stored in memory) $5 \leq x \leq 100$
0x6201	0x00	Runtime output voltage	UINT32	wo	Set a new output voltage in Volts (output must be run and not stored in memory) $60 \leq x \leq 400$
0x6202	0x00	Runtime frequency V/F	UINT32	wo	Set a new output frequency in Hz in mode V/F (output must be run and not stored in memory) $5 \leq \text{■■■■} \leq 100$
0x6203	0x00	Change phase order	UINT32	wo	Changes the output phase order (output must be run and not stored in memory) 1 → Phase RST (direct phase) 2 → Phase SRT (reverse phase)

Note 1:

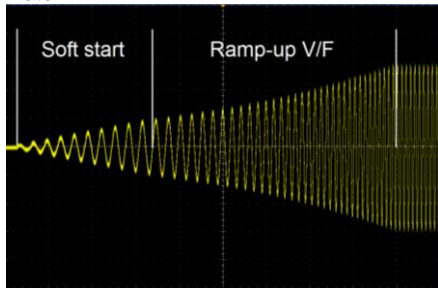

Example for Soft-start = 10 and V/F cycles = 1:
Soft start time = 0.62s and Ramp-up time = 1.7s
for changes from 16Hz to 50Hz

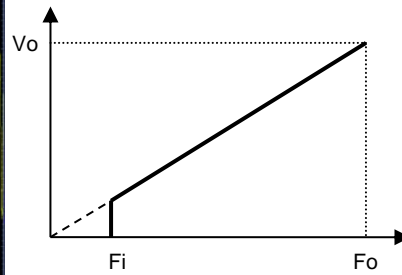

Mode V/F curve

Note 2 :

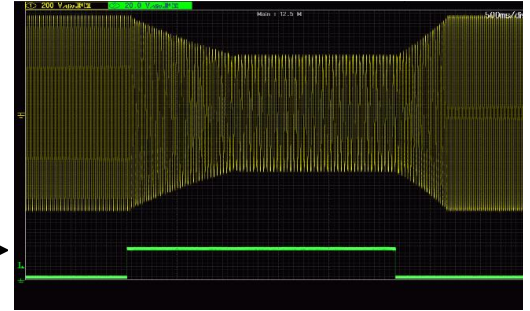

Example for change from 50Hz / 400V to 30Hz and 240V
with ramp-down of 2 cycles /Hz and ramp-up de 1 Cycle/Hz.
Yellow: output voltage and Green: Mid-Power input signal

WORKING PARAMETERS

Thermal protection		
Internal warning temperature (output alarm)	88	°C
Internal shutdown temperature	92	°C
Internal restart temperature	75	°C
Internal temperature of fan start-up	45	°C
Input voltage parameters		
	440Vac	
High input voltage shutdown instantaneous	460	Vac
High input voltage timed shutdown (t) (Input alarm)	450	Vac
<u>Start-up voltage</u>	350	Vac
<u>Low input voltage timed shutdown (t) (Input alarm)</u>	340	Vac
Low input voltage instantaneous shutdown	330	Vac
Time to shutdown (t)	500	ms
Output voltage parameters		
<u>Output voltage phase-phase</u>	400	Vac
Output under-voltage shutdown	< 85% of setting 1000ms	
Warning voltage (output alarm)	< 90% of setting 200ms	
<u>Initial start-up frequency</u>	5	Hz
Soft start duration	1 cycle	
<u>Ramp-up V/F</u>	1 Hz/cycle	
Output current parameters		
<u>Maximum continuous output current</u>	14.43	A
<u>Warning current (output alarm)</u>	13.71	A
Maximum overload I ² t	See figure below	
Time between restart attempts	4	s
Number of attempts of consecutive overload	5	
Working failures and reset		
Lock for continuous overload or internal failure	Unlimited time	
Reset time by input disconnection	> 2	min

Configurable parameters underlined

OVERLOAD PROTECTION

Protection against overloads and short-circuits	By current limiting at Iopk By I²t . The unit shutdowns when the current-time is over the continuous operation curve	
Overload protection recovery	Every 4 seconds after shutdown, the unit tries to restart up to 5 times. If the overload persists, the unit reminds shutdown until an input reconnection .	

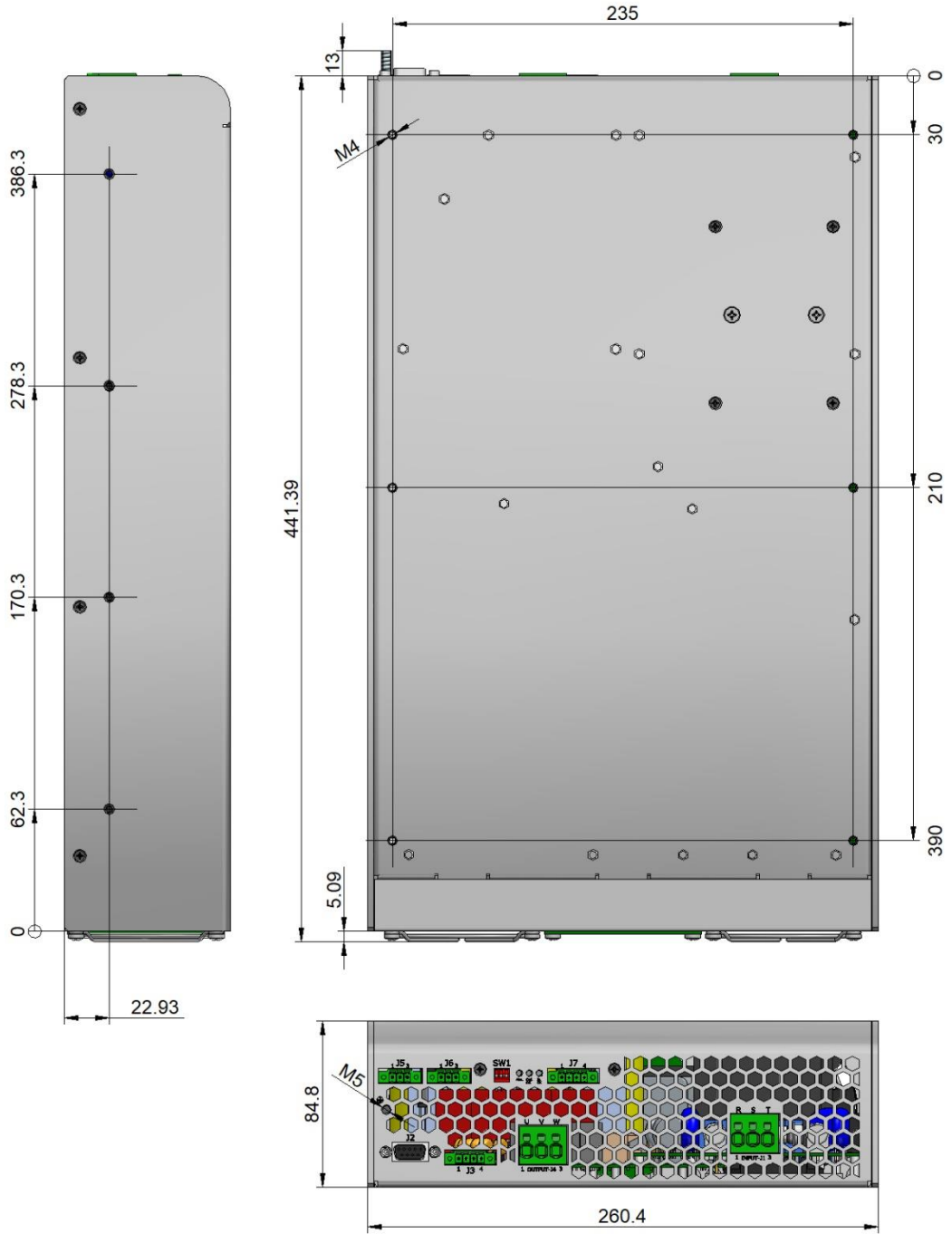

NOTE: All the fixing holes are M4. Maximum screw length inside de inverter 5mm. Max torque 2.5 Nm



ACCESSORIES

Description	Notes	CODE
Mounting brackets kit	Contains two brackets and screws	NP-9282
Aerial connectors J5 & J6	Aerial connectors for CAN interface	2 × 26011010
Aerial connectors J3 & J7	Aerial connectors for remote/config.input and alarms interfaces	2 × 26010493

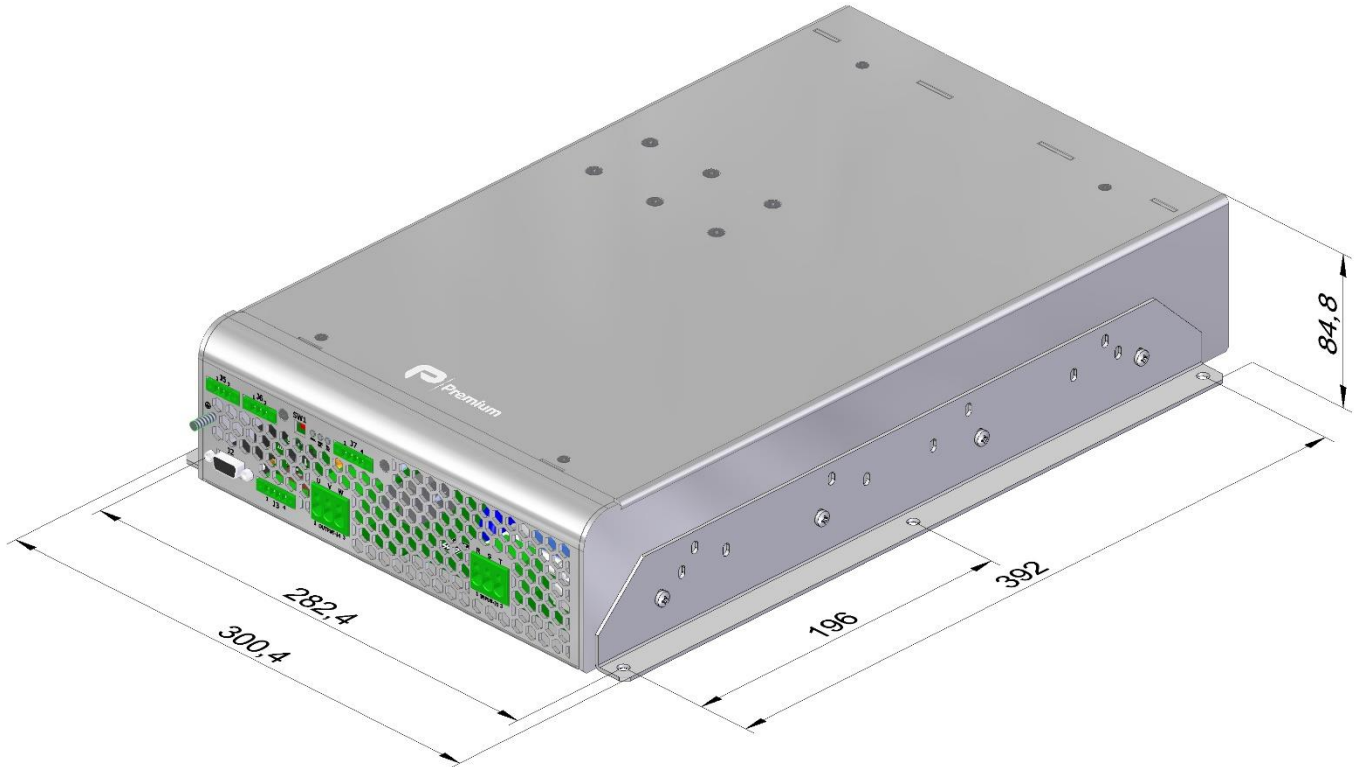



CE|UKCA EU, UKCA DECLARATION OF CONFORMITY

The undersigned, representing the following:

Manufacturer: PREMIUM, S. A.,
Address: C/ Dolors Aleu 19-21, 08908 L'Hospitalet de Llobregat, SPAIN

herewith declares that the product:

Type: AC/AC converter
Models: **VDX-10K-4501**

is in conformity with the provisions of the following directives or regulations:

2014/35/EU SI 2016 No 1101	Low voltage / The electrical equipment (safety) regulations
2014/30/EU SI 2016 No 1091	EMC / Electromagnetic compatibility regulations
2011/65/EU Annex II and its amendment 2015/863/EU SI 2012 No. 3032	RoHS / Restriction of the use of certain hazardous substances in electrical and electronic equipment

and that standards and/or technical specifications referenced below have been applied:

EN 62368-1: 2020	Safety. Audio/video, information and communication technology equipment
EN 61000-6-3: 2007	Generic emission standard
EN 61000-6-2: 2005	Generic immunity standard
EN 50155: 2021	Railway applications. Electronic equipment used on rolling stock material
EN 50121-3-2: 2016/A1:A19	Railway applications. EMC Rolling stock equipment

* Optional, See annexe

CE marking year: **2022**; UKCA marking year: **2022**

Notes:

For the fulfilment of this declaration the product must be used only for the aim that has been conceived, considering the limitations established in the instructions manual or datasheet.

L'Hospitalet de Llobregat, 26-05-2022

Albert Sole
Technical Director

PREMIUM S.A. is an ISO9001 and ISO14001
certified company by **Bureau Veritas**

ANNEXE

Applicable values for the different sections of the norm EN50155: 2021																																																														
4.3.1	Working altitude	Up to 2000m																																																												
4.3.2	Ambient temperature	For options B and T: Class OT2 (-40 to 55 °C): load < 100 % For options B and T: Class OT4 (-40 to 70 °C): load <62.5 % For options B and T: Class OT6 (-40 to 85 °C): load <25 %																																																												
4.3.3	Switch-on extended operating temp.	ST1																																																												
4.3.4	Rapid temperature variations	H1																																																												
4.3.5	Shocks and vibrations	According to EN61373:2010 Category 1 class B																																																												
4.3.6	EMC Electromagnetic Compatibility EN50121-3-2: 2016/A1:2019	<table border="1"> <thead> <tr> <th>Test</th> <th>Norm</th> <th>Port</th> <th>Frequency</th> <th>Limits</th> </tr> </thead> <tbody> <tr> <td rowspan="3">Radiated emissions</td> <td rowspan="3">EN61000-6-4</td> <td rowspan="3">Case</td> <td>30MHz...230MHz</td> <td>40dB(µV/m) Qpk at 10m</td> </tr> <tr> <td>230MHz...1GHz</td> <td>47dB(µV/m) Qpk at 10m</td> </tr> <tr> <td>1...3GHz 3...6GHz</td> <td>Do not apply Internal freq. < 108MHz</td> </tr> <tr> <td rowspan="2">Conducted emissions</td> <td rowspan="2">IEC55016-2-1</td> <td rowspan="2">Input</td> <td>150kHz...500kHz</td> <td>99dB(µV) Qpk</td> </tr> <tr> <td>500kHz...30MHz</td> <td>93dB(µV) Qpk</td> </tr> <tr> <td>THD total Harm. distortion</td> <td>EN61000-4-30</td> <td>Output</td> <td>50Hz-2KHz</td> <td><8%</td> </tr> </tbody> </table>	Test	Norm	Port	Frequency	Limits	Radiated emissions	EN61000-6-4	Case	30MHz...230MHz	40dB(µV/m) Qpk at 10m	230MHz...1GHz	47dB(µV/m) Qpk at 10m	1...3GHz 3...6GHz	Do not apply Internal freq. < 108MHz	Conducted emissions	IEC55016-2-1	Input	150kHz...500kHz	99dB(µV) Qpk	500kHz...30MHz	93dB(µV) Qpk	THD total Harm. distortion	EN61000-4-30	Output	50Hz-2KHz	<8%																																		
		Test	Norm	Port	Frequency	Limits																																																								
		Radiated emissions	EN61000-6-4	Case	30MHz...230MHz	40dB(µV/m) Qpk at 10m																																																								
					230MHz...1GHz	47dB(µV/m) Qpk at 10m																																																								
					1...3GHz 3...6GHz	Do not apply Internal freq. < 108MHz																																																								
		Conducted emissions	IEC55016-2-1	Input	150kHz...500kHz	99dB(µV) Qpk																																																								
					500kHz...30MHz	93dB(µV) Qpk																																																								
		THD total Harm. distortion	EN61000-4-30	Output	50Hz-2KHz	<8%																																																								
		<table border="1"> <thead> <tr> <th>Test</th> <th>Norm</th> <th>Port</th> <th>Severity</th> <th>Conditions</th> <th>P</th> </tr> </thead> <tbody> <tr> <td rowspan="2">Electrostatic discharge</td> <td rowspan="2">IEC61000-4-2</td> <td rowspan="2">Case</td> <td>±8kV</td> <td>Air (isolated parts)</td> <td rowspan="2">B</td> </tr> <tr> <td>±6kV</td> <td>Contact (conductive parts)</td> </tr> <tr> <td rowspan="4">Radiated high-frequency</td> <td rowspan="4">IEC61000-4-3</td> <td rowspan="4">X/Y/Z Axis</td> <td>20V/m</td> <td>0.08...1.0GHz M. 80% 1kHz</td> <td rowspan="4">A</td> </tr> <tr> <td>10V/m</td> <td>1.4...2.1GHz M. 80% 1kHz</td> </tr> <tr> <td>5V/m</td> <td>2.1...2.5GHz M. 80% 1kHz</td> </tr> <tr> <td>3V/m</td> <td>5.1...6GHz M. 80% 1kHz</td> </tr> <tr> <td rowspan="3">Fast transients</td> <td rowspan="3">IEC61000-4-4</td> <td>Input</td> <td>±2kV</td> <td rowspan="3">Tr/Th: 5/50 ns</td> <td rowspan="3">A</td> </tr> <tr> <td>Output</td> <td>±2kV</td> </tr> <tr> <td>Signal</td> <td>±2kV</td> </tr> <tr> <td rowspan="2">Surge</td> <td rowspan="2">IEC61000-4-5</td> <td>Input L to L</td> <td>±1kV</td> <td rowspan="2">Tr/Th: 1.2/50µs</td> <td rowspan="2">B</td> </tr> <tr> <td>Input L to PE</td> <td>±2kV</td> </tr> <tr> <td rowspan="3">Conducted RF</td> <td rowspan="3">IEC61000-4-6</td> <td>Input</td> <td>10V</td> <td rowspan="3">0.15...80MHz M. 80% 1kHz</td> <td rowspan="3">A</td> </tr> <tr> <td>Output</td> <td>10V</td> </tr> <tr> <td>Signal</td> <td>10V</td> </tr> <tr> <td>Magnetic field</td> <td>IEC61000-4-8</td> <td>X/Y/Z Axis</td> <td>300A/m</td> <td>0Hz, 16.7Hz, 50/60Hz</td> <td>A</td> </tr> </tbody> </table>	Test	Norm	Port	Severity	Conditions	P	Electrostatic discharge	IEC61000-4-2	Case	±8kV	Air (isolated parts)	B	±6kV	Contact (conductive parts)	Radiated high-frequency	IEC61000-4-3	X/Y/Z Axis	20V/m	0.08...1.0GHz M. 80% 1kHz	A	10V/m	1.4...2.1GHz M. 80% 1kHz	5V/m	2.1...2.5GHz M. 80% 1kHz	3V/m	5.1...6GHz M. 80% 1kHz	Fast transients	IEC61000-4-4	Input	±2kV	Tr/Th: 5/50 ns	A	Output	±2kV	Signal	±2kV	Surge	IEC61000-4-5	Input L to L	±1kV	Tr/Th: 1.2/50µs	B	Input L to PE	±2kV	Conducted RF	IEC61000-4-6	Input	10V	0.15...80MHz M. 80% 1kHz	A	Output	10V	Signal	10V	Magnetic field	IEC61000-4-8	X/Y/Z Axis	300A/m	0Hz, 16.7Hz, 50/60Hz	A
		Test	Norm	Port	Severity	Conditions	P																																																							
		Electrostatic discharge	IEC61000-4-2	Case	±8kV	Air (isolated parts)	B																																																							
					±6kV	Contact (conductive parts)																																																								
		Radiated high-frequency	IEC61000-4-3	X/Y/Z Axis	20V/m	0.08...1.0GHz M. 80% 1kHz	A																																																							
					10V/m	1.4...2.1GHz M. 80% 1kHz																																																								
					5V/m	2.1...2.5GHz M. 80% 1kHz																																																								
3V/m	5.1...6GHz M. 80% 1kHz																																																													
Fast transients	IEC61000-4-4	Input	±2kV	Tr/Th: 5/50 ns	A																																																									
		Output	±2kV																																																											
		Signal	±2kV																																																											
Surge	IEC61000-4-5	Input L to L	±1kV	Tr/Th: 1.2/50µs	B																																																									
		Input L to PE	±2kV																																																											
Conducted RF	IEC61000-4-6	Input	10V	0.15...80MHz M. 80% 1kHz	A																																																									
		Output	10V																																																											
		Signal	10V																																																											
Magnetic field	IEC61000-4-8	X/Y/Z Axis	300A/m	0Hz, 16.7Hz, 50/60Hz	A																																																									
P = Performance criteria, L= Line, PE= Protective Earth																																																														
4.3.7	Relative humidity	Up to 95%																																																												
7.2.7	Input reverse polarity protection	By external fuse																																																												
10.7	Protective coating for PCB assemblies	Class PC2																																																												
13.3	Tests list	<table border="0"> <tr> <td>1 Visual Inspection</td> <td>Routine</td> </tr> <tr> <td>2 Performance test</td> <td>Routine</td> </tr> <tr> <td>3 Power supply test</td> <td>Routine</td> </tr> <tr> <td>4 Insulation test</td> <td>Routine</td> </tr> <tr> <td>5 Low temperature storage test</td> <td>-</td> </tr> <tr> <td>6 Low temperature start-up test</td> <td>Type</td> </tr> <tr> <td>7 Dry heat test</td> <td>Type</td> </tr> <tr> <td>8 Cyclic damp heat test</td> <td>Type</td> </tr> <tr> <td>9 Salt mist test</td> <td>-</td> </tr> <tr> <td>10 Enclosure protection test (IP code)</td> <td>-</td> </tr> <tr> <td>11 EMC test</td> <td>Type</td> </tr> <tr> <td>12 Shocks and vibrations test</td> <td>Type</td> </tr> <tr> <td>13 Equipment stress screening test</td> <td>Routine: 8h at 40°C and load 100%</td> </tr> <tr> <td>14 Rapid Temperature variation test</td> <td>Type</td> </tr> </table>	1 Visual Inspection	Routine	2 Performance test	Routine	3 Power supply test	Routine	4 Insulation test	Routine	5 Low temperature storage test	-	6 Low temperature start-up test	Type	7 Dry heat test	Type	8 Cyclic damp heat test	Type	9 Salt mist test	-	10 Enclosure protection test (IP code)	-	11 EMC test	Type	12 Shocks and vibrations test	Type	13 Equipment stress screening test	Routine: 8h at 40°C and load 100%	14 Rapid Temperature variation test	Type																																
1 Visual Inspection	Routine																																																													
2 Performance test	Routine																																																													
3 Power supply test	Routine																																																													
4 Insulation test	Routine																																																													
5 Low temperature storage test	-																																																													
6 Low temperature start-up test	Type																																																													
7 Dry heat test	Type																																																													
8 Cyclic damp heat test	Type																																																													
9 Salt mist test	-																																																													
10 Enclosure protection test (IP code)	-																																																													
11 EMC test	Type																																																													
12 Shocks and vibrations test	Type																																																													
13 Equipment stress screening test	Routine: 8h at 40°C and load 100%																																																													
14 Rapid Temperature variation test	Type																																																													